

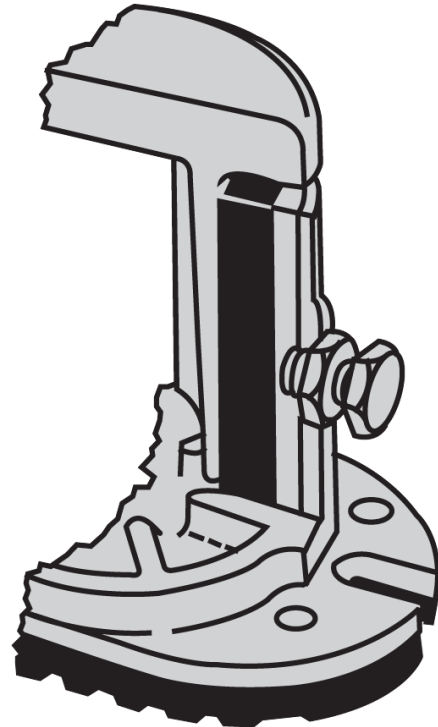

HOUSED SINGLE and MULTIPLE SPRING MOUNTS

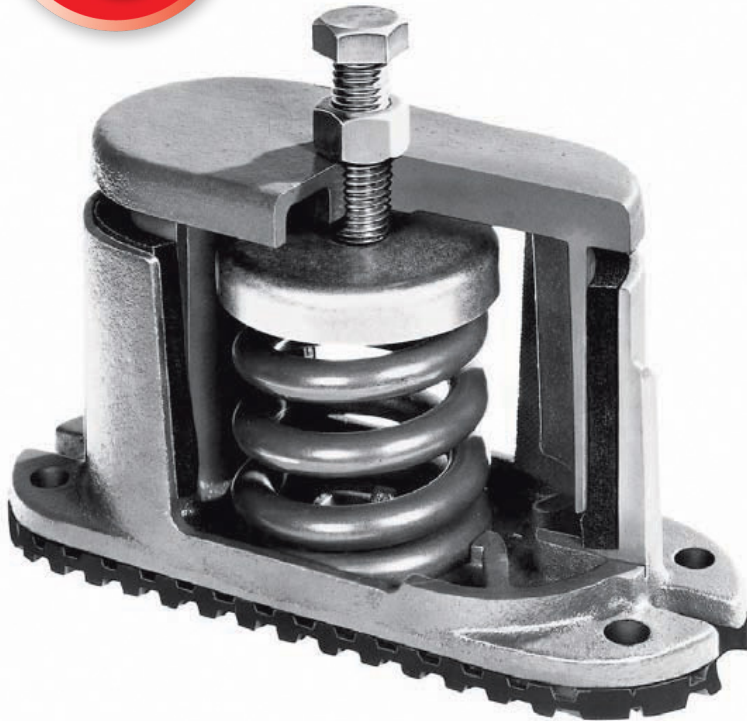

TYPE "C" Spring Mountings provide a packaged solution to troublesome vibration problems. Since the static deflection of the spring element is much greater than that provided by most rubber materials, these units will perform where it is necessary to establish low natural frequencies or to use a mounting that is more yielding than the supporting floor. Type "C" mountings are specifically designed for noise and vibration free application in critical areas on light concrete or wooden floors.

Semi-circular Neoprene sponge inserts limit movement during start and stop and prevent contact between the projections of the upper and lower semi-steel castings. These inserts are designed for a minimum of damping in all directions to allow the springs to function properly and develop installed efficiencies that are very close to the theoretical. Non-adjustable inserts are recommended for all air conditioning applications under compressors, air handling units, centrifugal fans and most other constant frequency vibration problems.

Other oil-resistant stocks may be substituted for Neoprene as new elastomers are developed.

TYPE "CS" mountings have built in adjustable snubbers for shock absorbing and high horizontal thrust applications. The damping, or housing drag, is varied by means of end adjustment bolts which change the pressure on the solid neoprene inserts. Tightening the snubbers reduces vertical movement and limits bounce. The same adjustment controls side motion and rock. Wear is negligible as damping is provided by the viscous-distortion of the neoprene inserts rather than by friction. Adjustable snubbers are recommended for applications under punch presses, drop hammers, clickers and other industrial equipment.

EXTERNAL adjustment mountings are used when equipment mounting holes are well centered and the mounting leveling and adjustment bolt is accessible from above.

INTERNAL adjustment mountings provide a means of attachment when it is preferable to shift the center of the mounting in relation to the equipment mounting hole or where there is no access for adjustment from above. Attachment to the equipment may be made either by an individually located tapped hole or by a type "W" friction pad cemented on top of the mounting. The internal spring adjustment bolt is reached through the side opening by means of an open end wrench. Both external and internal adjustment mountings are provided with type "W" acoustical friction pads on bottom to eliminate the need for bolting down on most installations.

1" & 2" Deflection SINGLE and MULTIPLE SPRING MOUNTS



TOP ACCESS ADJUSTMENT BOLT— Turn clockwise to load spring and maintain Free & Operating Height. Bolt length is suitable for 1" maximum Equipment Base thickness.

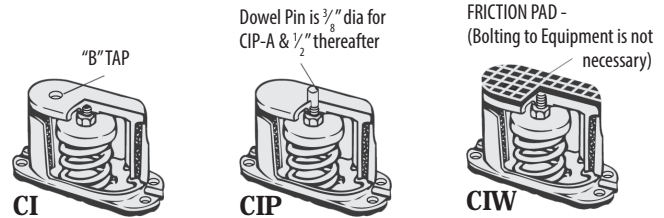
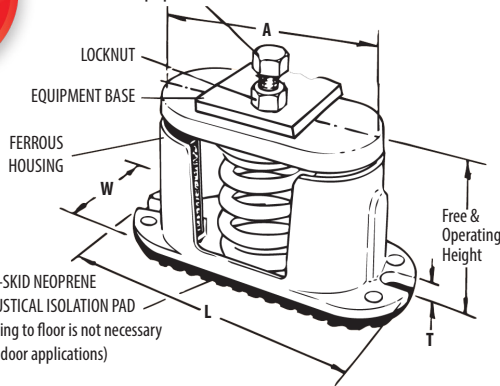

CI, CIP & CIW Mounts have **SIDE ACCESS INTERNAL ADJUSTMENT BOLTS**. Turn clockwise to load spring and maintain Free & Operating Height.

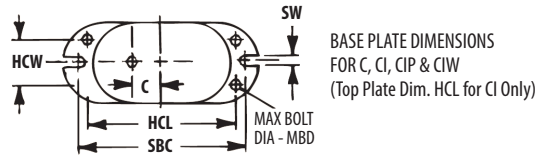

BASE PLATE DIMENSIONS FOR C, CI, CIP & CIW (Top Plate Dim. HCL for CI Only)

CS & CSI sizes start at C-1000. A & B sizes are not manufactured. Type C dimensions below apply.

TYPE C, CI, CIP & CIW DIMENSIONS (inches)[†]

Type	Size	CI Only			L	T	W	SW	HCL	HCW	MBD	SBC	Type C Adj. Bolt	1" Free & Op. Ht.			2" Free & Op. Ht.		
		A	B	C										C	CI&CIP	CIW	C	CI&CIP	CIW
C-	A	4	3/8	1	5 3/4	1/2	2 1/8	5/16	4 3/4	1	1/4	5	3/8 x 4	4 1/2	4 7/8	5 1/8	—	—	—
B & B2	5 3/4	1/2	1 1/4	8 1/4	1/2	2 3/4	7/16	6 1/2	1 1/2	3/8	7 1/4	1 1/2 x 4	5 3/8	6 1/8	6 3/8	6 1/2	6 1/8	6 3/8	
CI-	C & C2	6 3/8	1/2	1 1/4	8 1/8	9/16	3 1/2	7/16	7 1/4	1 3/4	3/8	7 1/8	5/8 x 4 1/2	5 3/8	6 1/8	6 3/8	6 1/2	6 1/8	7
CIP-	D & D2	9 3/4	5/8	††	12	9/16	3 1/2	7/16	10 3/8	1 3/4	3/8	11	5/8 x 4 1/2	6 1/8	6 1/2	6 3/4	6 1/8	7 1/2	7 3/4
CIW-	E & E2	12 1/8	5/8	2	12 3/4	5/8	6 3/8	—	11 3/8	5 1/8	1/2	—	3/4 x 5	6 1/8	6 1/2	6 3/4	6 1/8	7 1/2	7 3/4
F	16	3/4	††	16	5 1/2	7	—	14 1/2	5 1/8	5/8	—	Internal	6 3/8	6 3/4	7	7 1/8	7 1/2	8	
G	19 3/4	3/4	††	19 3/4	3 3/4	10	—	18 1/2	8 1/4	5/8	—	Adj. Only	6 3/8	6 3/4	7	7 1/8	7 3/4	8	

[†] Casting Dimensions vary ±1/8". ^{††} Hole is in center.

TYPE 1" DEFL. C, CI, CIP & CIW RATINGS

Type	Size	Rated Capacity (lbs)	Rated Defl (in)	Mount Constant (lbs/in)	Spring Color/Stripe
1" Defl.	A-45	45	1.60	28	Blue
	A-75	75	1.50	50	Orange
	A-125	125	1.33	94	Brown
	A-200	200	1.15	174	Black
	A-310	310	1.00	310	Yellow
	A-400	400	1.00	400	Green
	A-510	510	1.00	510	Red
	A-625	625	1.00	625	White
	B-65	65	2.10	31	Brown
	B-85	85	2.10	40	White/Black
	B-115	115	2.00	57	Silver
	B-150	150	2.00	77	Orange
	B-280	280	1.60	174	Green
	B-450	450	1.31	344	Red
	B-750	750	1.12	670	White
C-	B-1000	1000	1.00	1000	Blue
	B-1250	1250	1.00	1250	Gray
	B-1650	1650	1.00	1650	Black
	C-1000	1000	1.00	1000	Black
	C-1350	1350	1.00	1350	Yellow
	C-1750	1750	1.00	1750	Black
	C-2100	2100	1.00	2100	Yellow*
	C-2385	2385	1.00	2385	Yellow**
	C-2650	2650	1.00	2650	Red*
	C-2935	2935	1.00	2935	Red**
	D-3500	3500	1.00	3500	Black*
	D-4200	4200	1.00	4200	Yellow*
	D-4770	4770	1.00	4770	Yellow**
	D-5300	5300	1.00	5300	Red*
	D-5870	5870	1.00	5870	Red**
CI-	E-7000	7000	1.00	7000	Black*
	E-8400	8400	1.00	8400	Yellow*
	E-9540	9540	1.00	9540	Yellow**
	E-10600	10600	1.00	10600	Red*
	E-11740	11740	1.00	11740	Red**
	F-12600	12600	1.00	12600	Yellow*
	F-14310	14310	1.00	14310	Yellow**
	F-15900	15900	1.00	15900	Red*
	F-17610	17610	1.00	17610	Red**
	G-18900	18900	1.00	18900	Yellow*
	G-21465	21465	1.00	21465	Yellow**
	G-23850	23850	1.00	23850	Red*
	G-26415	26415	1.00	26415	Red**

*with RED core spring **with GREEN core spring

TYPE 2" DEFL. C, CI, CIP & CIW RATINGS

Type	Size	Rated Capacity (lbs)	Defl (in)	Rated Constant (lbs/in)	Mount Spring Color/Stripe	
2" Defl.	B-20	20	2.40	8	Tan	
	B-26	26	2.18	12	White/Blue	
	B-35	35	2.20	16	Purple	
	B-50	50	2.20	24	White/Red	
	B-65	65	2.10	31	Brown	
	B-85	85	2.10	40	White/Black	
	B-115	115	2.00	57	Silver	
	B-150	150	2.00	75	Orange	
	B2-210	210	2.12	99	Silver	
	B2-290	290	2.00	144	Blue	
C-	B2-450*	450	2.00	224	Tan	
	B2-680*	680	2.00	340	Gray	
	C2-125	125	2.50	50	Purple	
	C2-170	170	2.40	70	Brown	
	C2-210	210	2.30	90	Red	
	C2-260	260	2.20	120	White	
	C2-330	330	2.00	165	Black	
	C2-460	460	2.00	230	Blue	
	C2-610	610	2.00	305	Green	
	C2-880*	880	2.00	440	Gray	
	C2-1210*	1210	2.00	605	Silver*	
	C2-1540*	1540	2.00	770	Gray*	
	C2-1870*	1870	2.00	935	Silver*	
	CI-	D-C2-2420*	2420	2.00	1210	Silver*
		D-C2-3080*	3080	2.00	1540	Gray*
D-C2-3740*		3740	2.00	1870	Silver*	
E-C2-3520*		3520	2.00	1260	Gray	
E-C2-4840*		4840	2.00	2420	Gray*	
E-C2-6160*		6160	2.00	3080	Gray*	
E-C2-7480*		7480	2.00	3740	Silver*	

All springs without "*" have additional travel to solid equal to 50% of the rated deflection. *with RED core spring

***Published ratings allow minimum 25% additional travel to solid. For a full 50% specified minimum use the following ratings:**

Size	Derated Capacity (lbs)	Defl (in)	Size	Derated Capacity (lbs)	Defl (in)
B2-450	410	1.83	D-C2-3080	2570	1.67
B2-680	565	1.66	D-C2-3740	3120	1.67
C2-880	800	1.82	E-C2-3520	3200	1.82
C2-1210	1010	1.67	E-C2-4840	4040	1.67
C2-1540	1285	1.67	E-C2-6160	5145	1.67
C2-1870	1560	1.67	E-C2-7480	6245	1.67
D-C2-2420	2020	1.67			